



INTERNATIONAL APPLICATION PUBLISHED UNDER THE PATENT COOPERATION TREATY (PCT)

<p>(51) International Patent Classification ⁶ : C12Q 1/00, G01N 27/26, 27/30, C12Q 1/26, 1/32</p>	<p>A1</p>	<p>(11) International Publication Number: WO 99/13100 (43) International Publication Date: 18 March 1999 (18.03.99)</p>
<p>(21) International Application Number: PCT/US98/18275 (22) International Filing Date: 3 September 1998 (03.09.98) (30) Priority Data: 08/924,267 5 September 1997 (05.09.97) US (71) Applicant: ABBOTT LABORATORIES [US/US]; CHAD 0377/AP6D-2, 100 Abbott Park Road, Abbott Park, IL 60064-3500 (US). (72) Inventors: FORROW, Nigel, J.; 6 Grundy Close, Abingdon, Oxon OX14 3SD (GB). DAYLIFF, Simon, W.; 56 Foster Road, Abingdon, Oxon OX14 1YW (GB). (74) Agents: POPE, Lawrence, C. et al.; Abbott Laboratories, CHAD 0377/AP6D-2, 100 Abbott Park Road, Abbott Park, IL 60064-3500 (US).</p>	<p>(81) Designated States: AL, AM, AT, AU, AZ, BA, BB, BG, BR, BY, CA, CH, CN, CU, CZ, DE, DK, EE, ES, FI, GB, GE, GH, GM, HR, HU, ID, IL, IS, JP, KE, KG, KP, KR, KZ, LC, LK, LR, LS, LT, LU, LV, MD, MG, MK, MN, MW, MX, NO, NZ, PL, PT, RO, RU, SD, SE, SG, SI, SK, SL, TJ, TM, TR, TT, UA, UG, UZ, VN, YU, ZW, ARIPO patent (GH, GM, KE, LS, MW, SD, SZ, UG, ZW), Eurasian patent (AM, AZ, BY, KG, KZ, MD, RU, TJ, TM), European patent (AT, BE, CH, CY, DE, DK, ES, FI, FR, GB, GR, IE, IT, LU, MC, NL, PT, SE), OAPI patent (BF, BJ, CF, CG, CI, CM, GA, GN, GW, ML, MR, NE, SN, TD, TG).</p> <p>Published <i>With international search report. Before the expiration of the time limit for amending the claims and to be republished in the event of the receipt of amendments.</i></p>	

(54) Title: ELECTRODE WITH THIN WORKING LAYER

(57) Abstract

Disclosed is an improved electrode for use in an electrochemical sensor for measuring an analyte in a sample. The electrode includes a thin working layer whose thickness is from 2 to 10 microns. Also disclosed is an electrode strip that includes an electrode with a thin working layer. Typically, the thin working layer includes an enzyme and a redox mediator. In an electrode for measuring glucose, the enzyme can be glucose oxidase and the redox mediator can be ferrocene.

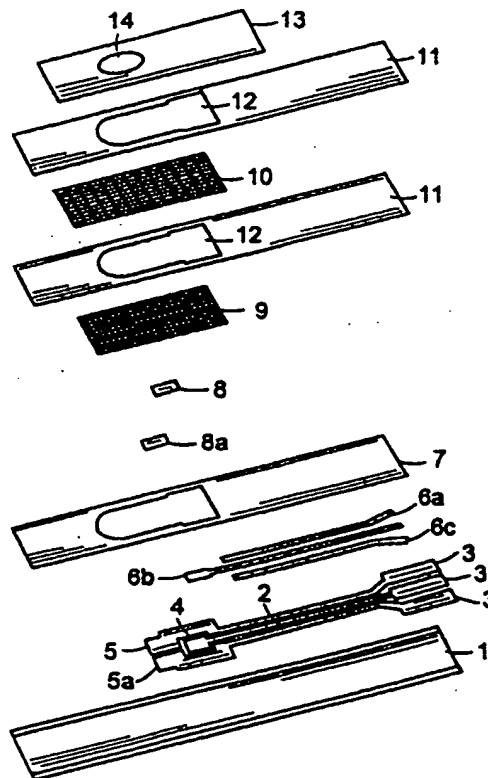

FOR THE PURPOSES OF INFORMATION ONLY

Codes used to identify States party to the PCT on the front pages of pamphlets publishing international applications under the PCT.

AL	Albania	ES	Spain	LS	Lesotho	SI	Slovenia
AM	Armenia	FI	Finland	LT	Lithuania	SK	Slovakia
AT	Austria	FR	France	LU	Luxembourg	SN	Senegal
AU	Australia	GA	Gabon	LV	Latvia	SZ	Swaziland
AZ	Azerbaijan	GB	United Kingdom	MC	Monaco	TD	Chad
BA	Bosnia and Herzegovina	GE	Georgia	MD	Republic of Moldova	TG	Togo
BB	Barbados	GH	Ghana	MG	Madagascar	TJ	Tajikistan
BE	Belgium	GN	Guinea	MK	The former Yugoslav Republic of Macedonia	TM	Turkmenistan
BF	Burkina Faso	GR	Greece	ML	Mali	TR	Turkey
BG	Bulgaria	HU	Hungary	MN	Mongolia	TT	Trinidad and Tobago
BJ	Benin	IE	Ireland	MR	Mauritania	UA	Ukraine
BR	Brazil	IL	Israel	MW	Malawi	UG	Uganda
BY	Belarus	IS	Iceland	MX	Mexico	US	United States of America
CA	Canada	IT	Italy	NE	Niger	UZ	Uzbekistan
CF	Central African Republic	JP	Japan	NL	Netherlands	VN	Viet Nam
CG	Congo	KE	Kenya	NO	Norway	YU	Yugoslavia
CH	Switzerland	KG	Kyrgyzstan	NZ	New Zealand	ZW	Zimbabwe
CI	Côte d'Ivoire	KP	Democratic People's Republic of Korea	PL	Poland		
CM	Cameroon	KR	Republic of Korea	PT	Portugal		
CN	China	KZ	Kazakhstan	RO	Romania		
CU	Cuba	LC	Saint Lucia	RU	Russian Federation		
CZ	Czech Republic	LI	Liechtenstein	SD	Sudan		
DE	Germany	LK	Sri Lanka	SE	Sweden		
DK	Denmark	LR	Liberia	SG	Singapore		
EE	Estonia						

ELECTRODE WITH THIN WORKING LAYER

Field of the Invention

The invention relates to electrochemical sensors, biomedical testing, and blood analysis.

5 Background of the Invention

Electrochemical assays for determining the concentration of enzymes or their substrates in complex liquid mixtures have been developed. For example, electrochemical sensor strips have been developed for the detection of blood
10 glucose levels. Electrochemical sensor strips generally include an electrochemical cell in which there is a working electrode and a reference electrode. The potential of the working electrode typically is kept at a constant value relative to that of the reference electrode.

15 Electrochemical sensor strips are also used in the chemical industry and food industry, to analyze complex mixtures. Electrochemical sensors are useful in biomedical research, where they can function as invasive probes, and for external testing (i.e., testing of blood obtained by a needle
20 and syringe, or a lance).

Typical electrochemical sensors for blood analysis measure the amount of analyte in a blood sample by using a working electrode coated with a layer containing an enzyme and a redox mediator and a reference electrode. When the
25 electrodes contact a liquid sample containing a species for which the enzyme is catalytically active, the redox mediator transfers electrons in the catalyzed reaction. When a voltage is applied across the electrodes, a response current results from the reduction or oxidation of the redox mediator at the
30 electrodes. The response current is proportional to the concentration of the substrate. Some sensors include a dummy electrode coated with a layer containing the redox mediator but lacking the enzyme. The response current at the dummy electrode represents a background response of the electrode in
35 contact with the sample. A corrected response is derived by subtracting the response of the dummy electrode from the response of the working electrode. This dummy subtraction

process substantially eliminates background interferences, thereby improving the signal-to-noise ratio in the electrode system.

Summary of the Invention

5 The invention features an electrode for use in an electrochemical sensor for measuring an analyte in a sample. The electrode includes a thin working layer. The thin working layer can be from 2 to 10 microns thick, and preferably is from 4 to 8 microns thick. Preferably, the thin working layer
10 includes an enzyme and a redox mediator. Preferably, it also includes a binder, a film former, and a filler. In an electrode for measuring glucose, the enzyme uses glucose as a substrate, and preferably the enzyme is glucose oxidase or glucose dehydrogenase. Preferably, the thin working
15 layer includes a redox mediator such as ferrocene, a ferrocene derivative, ferricyanide, or an osmium complex. The thin working layer of the electrode can be a printed layer, for example, a screen printed layer.

 The invention also features an electrode strip for use
20 in an electrochemical sensor for measuring an analyte in a sample. The electrode strip includes an electrode, which includes a thin working layer. The thin working layer can have a thickness of 2 to 10 microns. Preferably, the thickness is 4 to 8 microns. The thin working layer preferably includes an
25 enzyme and a redox mediator. Preferably, it also includes a binder, a film former, and a filler. In an electrode strip for measuring glucose, the enzyme uses glucose as a substrate, and preferably the enzyme is glucose oxidase or glucose dehydrogenase. Preferably, the thin working layer includes a
30 redox mediator such as ferrocene, a ferrocene derivative, ferricyanide, or an osmium complex. The thin working layer of the electrode can be a printed layer, for example, a screen printed layer. The electrode arrangement in the electrode strip can include a working electrode, a dummy electrode, and a
35 reference electrode. Preferably, the reference electrode is downstream of the working electrode, relative to sample flow.

The electrode strip can also include a hydrophilic mesh layer overlaying a sample loading area and the electrode arrangement.

In addition, the electrode strip can include a cover layer defining an upper boundary of a cell volume encompassing the electrode arrangement, and an aperture in the cover layer,
5 above the sample loading area.

Brief Description of the Drawings

Fig. 1 is an exploded view of an electrode strip according to one embodiment of the invention.

10 Fig. 2 is a perspective view of the assembled strip of Fig. 1

Fig. 3 is a graph of buffered glucose solution calibration slope ($\mu\text{A}/\text{mM}$) plotted against theoretical ink deposit (cu.in./sq.ft.).

15 Fig. 4 is a graph of blood glucose calibration slope ($\mu\text{A}/\text{mM}$) plotted against theoretical ink deposit (cu.in./sq.ft.).

Fig. 5 is graph of plasma/blood response ratio plotted against theoretical ink deposit (cu.in./sq.ft.).

20 Description of the Preferred Embodiments

The precision and accuracy of analyte measurements using an electrode sensor strip are improved by using electrodes with a thin working layer. The thin working layer has a thickness between about 2 microns and about 10 microns.
25 Preferably, it has a thickness between about 4 and about 8 microns. As used herein, "working layer" means a layer that contains electrochemical assay reaction components and forms a slurry with a sample.

The performance of an electrode strip depends, in part,
30 on its calibration slope. In general, electrochemical performance improves as its calibration slope increases. This is because the signal-to-noise ratio increases as the slope increases, and consequently, precision and accuracy are improved. This is particularly true at low analyte levels,
35 where noise is significant.

In printed electrode sensor strips, the calibration slope depends on the electrochemical activity of the printed layer on the surface of the working electrode. The electrochemical activity depends on the rate of dissolution and/or resuspension of the printed layer, upon contact with a sample.

The ink used to form the thin working layer on the working electrode includes an enzyme that uses the analyte as a substrate. The ink used to form the thin working layer on the dummy electrode does not include the enzyme. When the analyte is glucose, the enzyme is preferably glucose oxidase, and the ink contains from about 70 to about 700 glucose oxidase activity units/g of ink.

The ink used to form the thin working layer on the working electrode and dummy electrode includes a redox mediator. The redox mediator can be any electrochemically active compound that accepts or donates electrons to the enzyme. Examples of redox mediators are ferrocene, ferrocene derivatives, ferricyanide, and osmium complexes.

The ink can include a binder. The binder can be a polysaccharide. Suitable polysaccharides include guar gum, alginate, locust bean gum, carrageenan, and xanthan.

The ink can include an enzyme stabilizer. Examples of enzyme stabilizers are glutamate, trehalose, aspartate, DEAE dextran, lactitol, gelatin, and sucrose. A suitable range for stabilizer concentration is about 2 to about 11 weight percent, with about 5 weight percent being preferred.

The ink can include a film former. Suitable film formers include polyvinyl alcohol (PVA), polyvinyl pyrrole, cellulose acetate, carboxymethylcellulose, poly (vinyl oxazolidinone).

The ink can include a filler. The filler can be conducting or nonconducting. Suitable fillers include graphite, titanium dioxide, silica, and alumina. Preferably, the filler is a carbonaceous conductor.

The ink can include a defoaming agent. Suitable

defoaming agents include a blend of non-ionic fats, an oil, a wax, and a synthetic non-ionic surfactant block co-polymer of propylene oxide and ethylene oxide.

The ink can include a pH buffer. Suitable pH buffers
5 include imidazole, HEPES, PBS, and the like. Preferably, the buffer is adjusted to about pH 7.5.

An electrode strip suitable for a thin printed working layer according to this invention is described in Carter et al., U.S. Patent No. 5,628,890, which is incorporated herein by
10 reference. An electrode strip suitable for a thin printed working layer according to this invention is illustrated in Figs. 1 and 2.

Referring to Figs. 1 and 2, an electrode support 1, typically made of PVC, polycarbonate, or polyester, supports
15 three printed tracks of electrically conducting carbon ink 2. The printed tracks 2 define the positions of the working electrode 5, dummy electrode 5a, reference electrode 4, and electrical contacts 3. The contacts 3 fit into a compatible meter (not shown).

The elongated portions of the printed tracks 2 of
20 electrically conducting carbon ink are each overlaid with a silver/silver chloride particle track 6a, 6b, and 6c. Except for the electrode areas, the silver/silver chloride particle tracks 6a, 6b, 6c are overlaid with a layer of hydrophobic,
25 electrically insulating material 7. The hydrophobic electrically insulating material is useful to surround the area containing the electrode arrangement. Hydrophobicity of the electrically insulating material is useful for confining the sample to the area containing the electrode arrangement. A
30 preferred electrically insulating material is Sericol™ (Sericol Ltd., Broadstairs, Kent, UK).

The thin working areas of the electrodes 8, 8a are formed from the ink described above. The ink is deposited on electrode areas 5, 5a of carbon tracks 2. Preferably, the ink
35 is deposited by a conventional printing technique, e.g., screen

printing, lithography, gravure, and flexographic printing. Screen printing is particularly preferred.

Referring to Fig. 1, two surfactant coated mesh layers 9, 10 overlay the electrodes 4, 5, 5a. The mesh layers protect the printed components from physical damage. They also facilitate wetting of the electrodes by the aqueous sample. Finely woven nylon is suitable for the mesh layers. Alternatively, any woven or non-woven material can be used. For a detailed discussion of the mesh layers see Carter et al., U.S. Patent No. 5,628,890, which is herein incorporated by reference.

If the mesh material is hydrophobic (e.g., nylon or polyester), it is coated with a surfactant. If a hydrophilic mesh is used, the surfactant coating can be omitted. Hydrophilicity of the mesh allows the sample to wick along the mesh layer to the electrodes. The wicking properties of the mesh can be controlled by changing the type or amount of surfactant on the mesh material. Various surfactants are suitable for coating the mesh material. A preferred surfactant is FC 170C FLUORAD™ fluorochemical surfactant (3M, St. Paul, MN). FLUORAD™ is a solution of a fluoroaliphatic oxyethylene adduct, lower polyethylene glycols, 1,4-dioxane, and water. A preferred surfactant loading for most applications is from about 15-20 µg/mg of mesh (e.g., about 1.0 percent w/w). The preferred surfactant loading will vary depending on the type of mesh and surfactant used and the sample to be analyzed. It can be determined empirically by observing flow of the sample through the mesh with different levels of surfactant. In general, a loading of 1-10 µg/mg of mesh is preferred.

The upper mesh layer 10 helps to control the influx of sample as it travels from the sample application area toward the electrode arrangement. The upper mesh layer 10 does so by providing a space to accommodate air displaced by the sample. Spacing of the relatively large filaments in the upper mesh layer 10, perpendicular to the direction of sample flow, helps

to control the sample flow by presenting repeated physical barriers to the movement of the sample, as it travels along the sample transfer path.

Preferably, the upper mesh layer 10 is woven, and is
5 coarser than the lower mesh layer 9. Preferably, the thickness of the upper mesh layer is between about 100 microns and about 1000 microns. More preferably, it is from about 100 to about 150 microns.

The mesh layers 9, 10 are held in place by a dielectric
10 coating 11, which impregnates the periphery of the mesh layers 9, 10. The dielectric coating 12 can be applied by screen printing. The dielectric coating 12 covers no portion of the electrodes 4, 5, 5a. Preferably, the dielectric coating is hydrophobic, so that it efficiently confines the sample.
15 Preferably, the hydrophobic dielectric coating is POLYPLAST™ (Sericol Ltd., Broadstairs, Kent, UK). More preferably, it is SERICARD™ (Sericol).

The uppermost layer on the electrode strip is a cover
layer 13. Preferably, the cover layer 13 is substantially
20 impermeable. A suitable material for formation of the cover layer 13 is a flexible polyester tape.

The cover layer 13 defines an upper boundary of the
electrochemical cell volume, and thus, it determines the
maximum depth of the aqueous sample. The cover layer 13 fixes
25 the upper boundary of the cell volume at a predetermined height, which depends on the thickness of the mesh layers 9, 10. The cell height, and thus maximum sample depth, is selected to ensure a suitably high solution resistance.

The cover layer 13 has an aperture 14 for sample access
30 to the underlying mesh layers 9, 10. The aperture 14 is located over a sample loading area, which is adjacent to the upstream ends of the working electrode 5 and dummy electrode 5a. The aperture 14 can be of any suitable size large enough to allow sufficient volume of sample to pass through to the
35 mesh layers 9, 10. It should not be so large as to expose any

portion of the electrodes 4, 5, 5a. The aperture 14 can be formed in the cover layer 13 by any suitable method, e.g., die punching.

Cover layer 13 is peripherally affixed to the strip by means of a suitable adhesive. Preferably, the cover layer 13 is affixed by means of a hot melt adhesive. The hot melt adhesive typically has a coating weight between 10 and 50 g/m², preferably from 20 to 30 g/m². Pressure sensitive adhesives or other suitable adhesives can also be used. When a heat sensitive dielectric coating 11 is used, e.g., SERICARD™, heat welding of the cover layer 13 should be carried out in a manner that does not damage the dielectric coating 11.

Optionally, the upper surface of the cover layer 32 can be coated with a layer of silicone or other hydrophobic coating. This helps to drive the applied sample onto the hydrophobic mesh layers 9, 10, thus facilitating the application of small volumes.

Referring to Fig. 2, an electrode strip of the invention is connected, via electrode contacts 3, to a compatible meter (not shown), and then a sample is placed in aperture 14.

Any of various known methods can be used to produce a thin working layer according to this invention. For example, the thin working layer can be screen printed, using a suitable electrode printing ink. When the thin working layer is applied by screen printing, layer thickness can be controlled by screen mesh size. For example, with a suitable ink, a screen mesh size of 400 can be used to produce a thin working layer of 2 to 10 microns. A suitable ink for screen printing a thin working layer is a low viscosity ink. Viscosity can be adjusted using methods well known in the art.

When screen printing is used, working layer thickness also can be controlled by adjusting the thickness of the screen emulsion. The amount of ink deposited, i.e., print thickness, also can be controlled by adjusting other printer parameters,

such as breakaway/snap-off distance, squeegee pressure, squeegee speed and squeegee durometer (hardness).

The following examples are intended to be illustrative of, and not limiting to, the invention.

5 Example 1: Dependence of buffered glucose calibration slope on print thickness of electrode working area

Electrode strips were constructed essentially as described in U.S. Patent No. 5,628,890, using different working
10 electrode inks and print screens with 250, 325, or 400 mesh size. Buffered solutions containing known glucose concentrations were prepared. Aliquots of these standard solutions were applied to the electrode strips, and steady state responses were obtained using a compatible meter system.
15 Calibration slopes were calculated as μA current per mM glucose. Fig. 3 shows the electrode response slope ($\mu\text{A}/\text{mM}$), measured with buffered glucose solutions.

Referring to Figure 3, the calibration slope for a buffer standard solutions of analyte, i.e., glucose, decreased
20 as the theoretical volume of ink decreased. The reduction in current response correlated with the reduction in total amount of assay components, as working area layer thickness decreased.
Example 2: Dependence of blood
glucose calibration slope on print
25 thickness of electrode working area

Electrode strips were produced as in Example 1. Known amounts of glucose were added to anticoagulated venous blood samples. Aliquots of these samples were applied to the electrode strips, and steady state responses were obtained
30 using a compatible meter system. Calibration slopes were calculated as μA current per mM glucose. Fig. 4 shows the electrode response slope ($\mu\text{A}/\text{mM}$), measured with spiked venous blood. Surprisingly, the response remained essentially constant as the theoretical working electrode working area

print thickness decreased. This contrasted with the result observed with glucose control solutions, and this result was not predicted from conventional electrochemical theory.

Example 3: Relationship between electrode
5 working area print thickness and electrode
response to glucose in venous blood and plasma

Electrode strips were produced as in Examples 1 and 2. Anticoagulated venous blood samples were divided into two aliquots. Red blood cells were removed from one aliquot by
10 conventional means and discarded. Samples of plasma and whole
blood were applied to the electrode strips, and steady state responses were obtained using a compatible meter system. The ratios of the electrode responses (μA) in plasma and whole
15 blood were calculated and plotted against theoretical ink
deposition (electrode working area print thickness) in Fig. 5.

The ratio of the plasma and whole blood response indicated the sensitivity of the electrodes to sample hematocrit. As the ratio approached 1.0, the sensor response was less dependent on the sample hematocrit. Fig. 5 shows that the plasma/blood
20 ratio, and therefore the hematocrit sensitivity of the sensor, was reduced as the electrode working area print thickness decreased. The reduction in red cell fouling improved the precision and accuracy of the measurement system for whole blood analysis.

25 Example 4: Print thickness measurements
using Sloan Dektak II Profilometer

The thicknesses of ink deposits (electrode thin working layers) on electrode strips of this invention, manufactured under standard conditions, were determined by profilometric
30 measurements. Similar measurements were carried out on comparable ink deposits printed on glass. For comparison, corresponding measurements were performed on prior art electrode strips (Medisense G2a strips).

All profilometry measurements were made using a Sloan
35 Dektak II Profilometer at the AEA Science and Technology

Centre, Harwell, U.K. Samples were measured in triplicate. The working ink print areas of G2a (prior art) strips and G2b strips were exposed by removing the nylon mesh prior to measurements. Samples of G2a and G2b inks were also printed
5 directly onto a glass substrate (using standard manufacturing procedures and equipment). G2a inks were printed using 325 mesh and G2b using 400 mesh screen sizes.

G2a print thickness on strips ranged from 5.8 to 10.4 μm . It was not possible to record the thickness of G2b ink on
10 strip samples even though the profilometer is able to detect height differences over 0.1 μm . This indicates that the G2b ink deposit was less than 1 μm in thickness, or that the ink embedded into the underlying carbon track during printing. Measurements showed the carbon track on G2a strips to be
15 approximately 20 μm thick. The measured thickness of the carbon track plus working area ink on G2b strips was only about 16 μm . This indicated that the carbon track on the G2b strip had been exposed to a greater level of compression during manufacture.

20 When printed onto a glass substrate, the G2a working area print thickness was measured at 14 μm . The G2b working area print was measured at 8 μm . The use of glass in this comparative test substantially eliminated measurement error caused by embedding of ink into the surface onto which the ink
25 was printed. These test results indicated that the thin working layer according to this invention was substantially thinner than prior art working area layers, even though direct measurement of layer thickness can be complicated by embedding of ink into the electrode support.

30 Other embodiments are within the following claims.

Claims

We claim:

1. An electrode for use in an electrochemical sensor for measuring an analyte in a sample, comprising a thin working layer, said thin working layer having a thickness of 2 to 10 microns.
2. The electrode of claim 1, wherein said thin working layer has a thickness of 4 to 8 microns.
3. The electrode of claim 1, wherein said thin working layer comprises an enzyme and a redox mediator.
4. The electrode of claim 3, wherein said thin working layer further comprises a binder, a film former, and a filler.
5. The electrode of claim 3, wherein said enzyme uses glucose as a substrate.
6. The electrode of claim 5, wherein said enzyme is selected from the group consisting of glucose oxidase and glucose dehydrogenase.
7. The electrode of claim 3, wherein said redox mediator is selected from the group consisting of ferrocene, a ferrocene derivative, ferricyanide, an osmium complex.
8. The electrode of claim 1, wherein said thin working layer is a printed layer.
9. The electrode of claim 8, wherein said thin working layer is a screen printed layer.

10. An electrode strip for use in an electrochemical sensor for measuring an analyte in a sample, comprising an electrode arrangement, which comprises an electrode comprising a thin working layer, said layer thin working layer having a
5 thickness of 2 to 10 microns.

11. The electrode strip of claim 10, wherein said thin working layer has a thickness of 4 to 8 microns.

12. The electrode strip of claim 10, wherein said thin working layer comprises an enzyme and a redox mediator.

10 13. The electrode strip of claim 12, wherein said thin working layer further comprises a binder, a film former, and a filler.

14. The electrode strip of claim 12, wherein said enzyme uses glucose as a substrate.

15 15. The electrode strip of claim 14, wherein said enzyme is selected from the group consisting of glucose oxidase and glucose dehydrogenase.

16. The electrode strip of claim 12, wherein said redox mediator is selected from the group consisting of
20 ferrocene, a ferrocene derivative, ferricyanide, an osmium complex.

17. The electrode strip of claim 10, wherein said thin working layer is a printed layer.

18. The electrode strip of claim 17, wherein said thin
25 working layer is a screen printed layer.

19. The electrode strip of claim 10, wherein said electrode arrangement comprises a working electrode, a dummy electrode, and a reference electrode.

20. The electrode strip of claim 19, said reference electrode is downstream of said working electrode, relative to sample flow.

21. The electrode strip of claim 10, further comprising a hydrophilic mesh layer overlaying a sample loading area and said electrode arrangement.

22. The electrode strip of claim 21, further comprising a cover layer defining an upper boundary of a cell volume encompassing said electrode arrangement, and an aperture in said cover layer, said aperture located above said sample loading area.

1/3

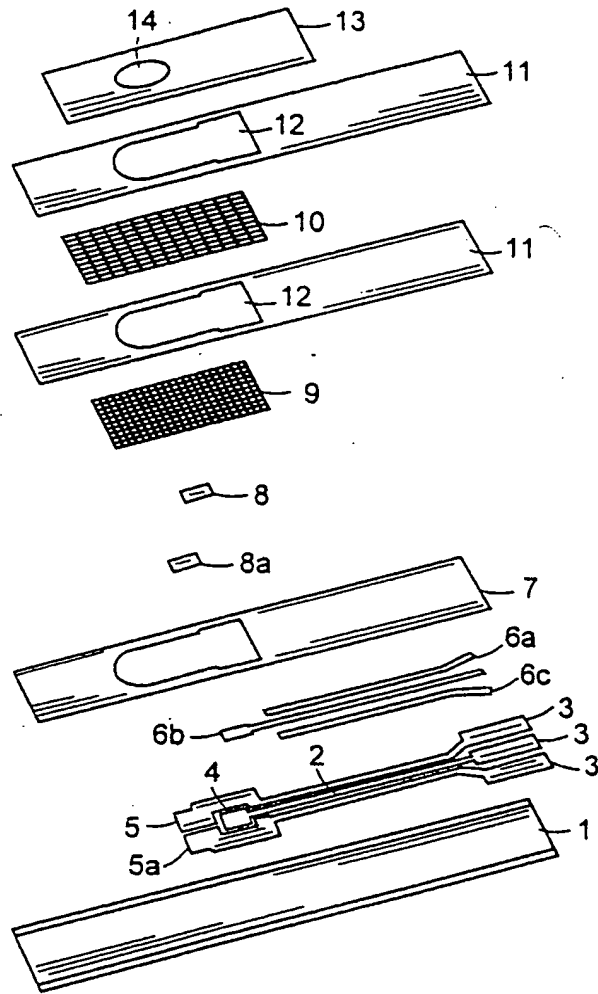

FIG. 1

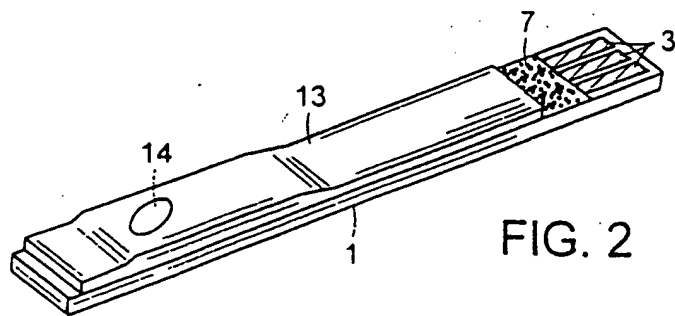

FIG. 2

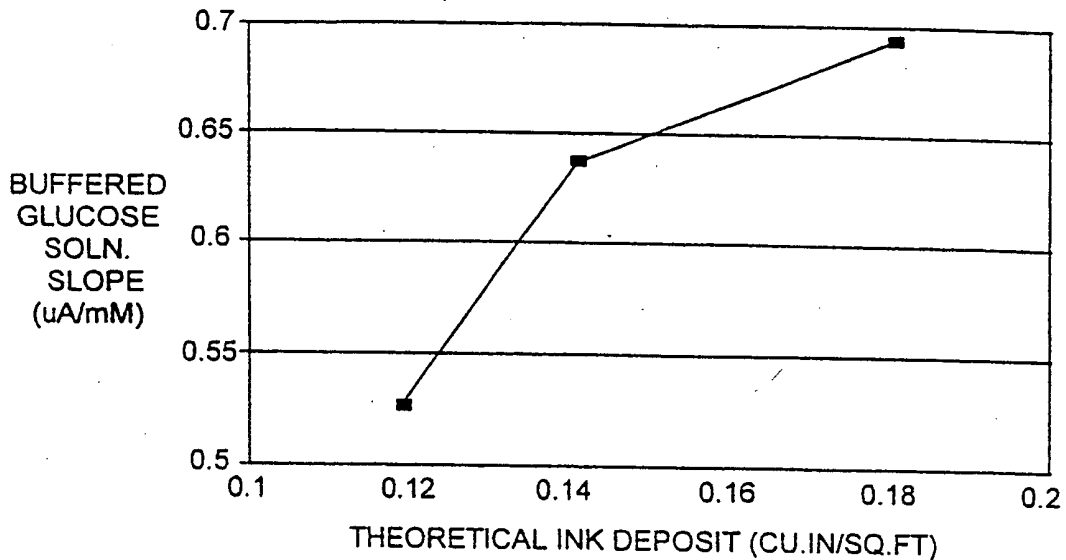

FIG. 3

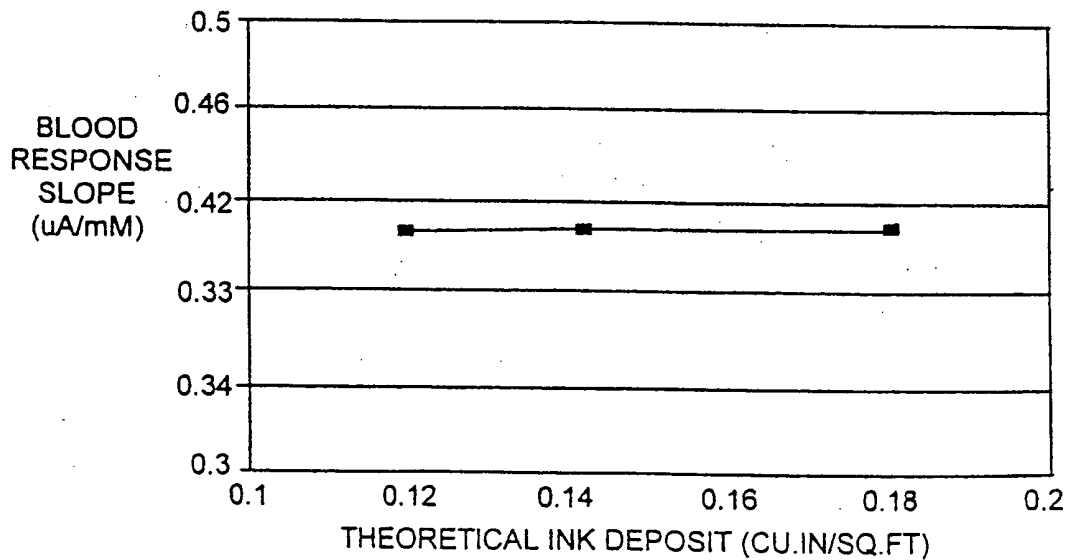

FIG. 4

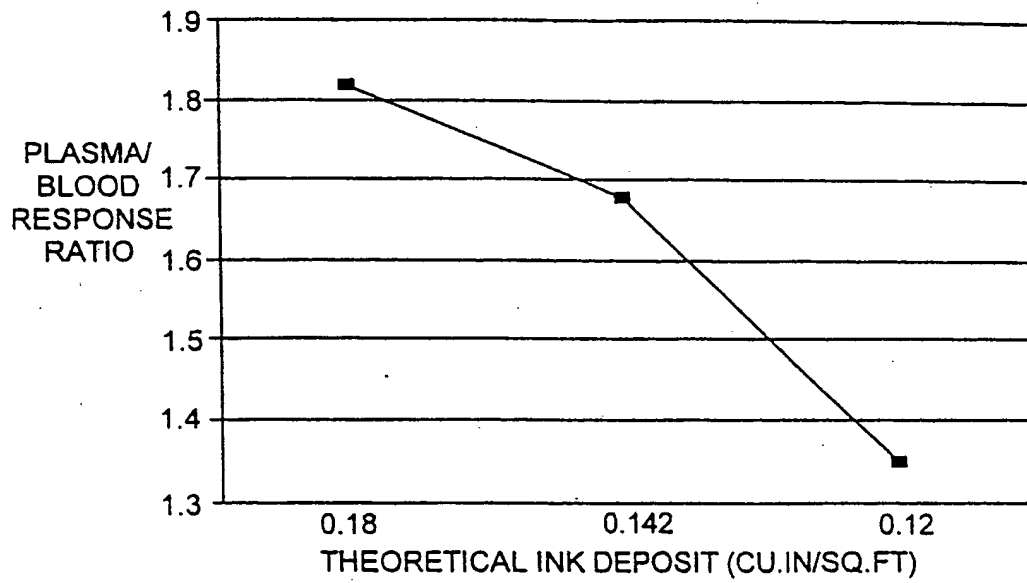

FIG. 5

INTERNATIONAL SEARCH REPORT

International Application No

PCT/US 98/18275

A. CLASSIFICATION OF SUBJECT MATTER

IPC 6 C12Q1/00 G01N27/26 G01N27/30 C12Q1/26 C12Q1/32

According to International Patent Classification (IPC) or to both national classification and IPC

B. FIELDS SEARCHED

Minimum documentation searched (classification system followed by classification symbols)

IPC 6 C12Q

Documentation searched other than minimum documentation to the extent that such documents are included in the fields searched

Electronic data base consulted during the international search (name of data base and, where practical, search terms used)

C. DOCUMENTS CONSIDERED TO BE RELEVANT

Category *	Citation of document, with indication, where appropriate, of the relevant passages	Relevant to claim No.
X	EP 0 690 134 A (CIBA CORNING DIAGNOSTICS CORP) 3 January 1996	1, 3-6, 8-10, 12-15, 17-22
Y	see page 2, line 31 - page 5, line 34	7, 16
A	see claims 1, 2, 7, 10, 11, 19; examples 2, 9	2, 11
Y	WO 95 22597 A (BOEHRINGER MANNHEIM CORP) 24 August 1995 see page 1, line 9 - line 25	7, 16
A	see page 15, line 1 - line 30; table 1 see page 18, line 18 - line 21; claims 1, 9-12	1-6, 8-15, 17-22
	--- -/--	

Further documents are listed in the continuation of box C.

Patent family members are listed in annex.

* Special categories of cited documents:

- "A" document defining the general state of the art which is not considered to be of particular relevance
- "E" earlier document but published on or after the international filing date
- "L" document which may throw doubts on priority claim(s) or which is cited to establish the publication date of another citation or other special reason (as specified)
- "O" document referring to an oral disclosure, use, exhibition or other means
- "P" document published prior to the international filing date but later than the priority date claimed

- "T" later document published after the international filing date or priority date and not in conflict with the application but cited to understand the principle or theory underlying the invention
- "X" document of particular relevance; the claimed invention cannot be considered novel or cannot be considered to involve an inventive step when the document is taken alone
- "Y" document of particular relevance; the claimed invention cannot be considered to involve an inventive step when the document is combined with one or more other such documents, such combination being obvious to a person skilled in the art.
- "&" document member of the same patent family

Date of the actual completion of the international search

13 January 1999

Date of mailing of the international search report

05/02/1999

Name and mailing address of the ISA

European Patent Office, P.B. 5818 Patentlaan 2
NL - 2280 HV Rijswijk
Tel. (+31-70) 340-2040, Tx. 31 651 epo nl,
Fax: (+31-70) 340-3018

Authorized officer

Gundlach, B

INTERNATIONAL SEARCH REPORT

International Application No

PCT/US 98/18275

C.(Continuation) DOCUMENTS CONSIDERED TO BE RELEVANT		
Category *	Citation of document, with indication, where appropriate, of the relevant passages	Relevant to claim No.
A	US 5 628 890 A (CARTER NIGEL F ET AL) 13 May 1997 cited in the application see the whole document ---	1-22
A	EP 0 351 891 A (MEDISENSE INC) 24 January 1990 see page 2, line 13 - line 19; claims 1-9 ---	1-22
A	EP 0 230 472 A (MATSUSHITA ELECTRIC IND CO LTD) 5 August 1987 see claims 1,2,8; example 1 ---	1-22
P,A	US 5 798 031 A (CHARLTON STEVEN C ET AL) 25 August 1998 see the whole document -----	1-22

INTERNATIONAL SEARCH REPORT

Information on patent family members

International Application No

PCT/US 98/18275

Patent document cited in search report	Publication date	Patent family member(s)	Publication date
EP 0690134 A	03-01-1996	US 5494562 A	27-02-1996
		AU 1229595 A	11-01-1996
		CA 2138856 A	28-12-1995
		JP 8193969 A	30-07-1996
		PL 306936 A	08-01-1996
		US 5529676 A	25-06-1996
		US 5573647 A	12-11-1996
		US 5616222 A	01-04-1997
		US 5582698 A	10-12-1996
		US 5711868 A	27-01-1998
		US 5601694 A	11-02-1997
US 5770028 A	23-06-1998		
WO 9522597 A	24-08-1995	US 5437999 A	01-08-1995
		CA 2183865 A	24-08-1995
		EP 0753051 A	15-01-1997
		JP 9509740 T	30-09-1997
US 5628890 A	13-05-1997	CA 2159553 A	30-03-1997
		JP 9222411 A	26-08-1997
EP 0351891 A	24-01-1990	GB 2154003 A	29-08-1985
		AU 572138 B	05-05-1988
		AU 2775584 A	08-11-1984
		CA 1226036 A	25-08-1987
		DE 3485554 A	16-04-1992
		DE 3486221 D	04-11-1993
		DE 3486221 T	27-01-1994
		EP 0127958 A	12-12-1984
		EP 0351892 A	24-01-1990
		JP 9325127 A	16-12-1997
		JP 7072727 B	02-08-1995
		JP 60017344 A	29-01-1985
		US 5682884 A	04-11-1997
		US 5727548 A	17-03-1998
		US 5820551 A	13-10-1998
		AU 616169 B	24-10-1991
		AU 1239188 A	07-07-1988
		US 5509410 A	23-04-1996
		AU 569076 B	21-01-1988
		AU 2775384 A	08-11-1984
		AU 580257 B	12-01-1989
		AU 2775484 A	08-11-1984
		CA 1219040 A	10-03-1987
		CA 1223638 A	30-06-1987
		CA 1218704 A	03-03-1987
		CA 1220818 A	21-04-1987
		EP 0125867 A	21-11-1984
		EP 0125136 A	14-11-1984
		EP 0125137 A	14-11-1984
		EP 0125139 A	14-11-1984
		US 4758323 A	19-07-1988
		US 4711245 A	08-12-1987
		EP 0230472 A	05-08-1987
JP 62232554 A	13-10-1987		
JP 6048256 B	22-06-1994		
JP 61294351 A	25-12-1986		

INTERNATIONAL SEARCH REPORT

Information on patent family members

International Application No

PCT/US 98/18275

Patent document cited in search report	Publication date	Patent family member(s)	Publication date
EP 0230472 A		JP 1915067 C	23-03-1995
		JP 6040088 B	25-05-1994
		JP 62108145 A	19-05-1987
		JP 1949170 C	10-07-1995
		JP 6076984 B	28-09-1994
		JP 62108146 A	19-05-1987
		JP 1915084 C	23-03-1995
		JP 6040089 B	25-05-1994
		JP 62137559 A	20-06-1987
		DE 3687646 A	11-03-1993
		WO 8607632 A	31-12-1986
		US 4897173 A	30-01-1990
		US 5185256 A	09-02-1993
US 5798031 A	25-08-1998	AU 6482198 A	12-11-1998
		EP 0878708 A	18-11-1998
		JP 10318971 A	04-12-1998

THIS PAGE BLANK (USPTO)